

## FEEDING A MEMBRANE-LESS MICROBIAL FUEL CELL BY MIXED MUNICIPAL AND INDUSTRIAL WASTEWATER

Barbara WŁODARCZYK<sup>1</sup>, Paweł P. WŁODARCZYK

Institute of Environmental Engineering and Biotechnology, University of Opole, Opole, Poland

### Abstract

Due to the constant growth of the world's population, the amount of generated wastewater is also constantly increasing. One of the devices that can use wastewater as a raw material for energy production is a microbial fuel cell (MFC). MFCs technology is constantly evolving. However, to increase its use, it is necessary to improve its efficiency. There are various possibilities to ensure this, such as the use of new electrode materials, new cell designs, or the use of wastewaters from different sources. In this paper the analysis of MFC operation (cell voltage, power, and current density) fed by mixed municipal and industrial wastewaters was shown. Moreover, the change in time of COD was analyzed. Due to cost reduction the membrane-less microbial fuel cell (ML-MFC) was chosen. It was noted that the addition of concentrated process wastewater increases the COD reduction time in the ML-MFC. An increase of generated bioelectricity during fed ML-MFC by mixed municipal and industrial (process wastewater from yeast production) wastewater was demonstrated. The highest values of average cell voltage (598 mV), maximum power (4.47 mW) and maximum current density (0.26 mA·cm<sup>-2</sup>) were obtained for a 10% share of yeast process wastewater in the mixed wastewater, which fed the ML-MFC.

**Keywords:** bioelectricity, bioenergy, microbial fuel cell (MFC), yeast process wastewater, environmental engineering, renewable energy sources, wastewater treatment, COD reduction, environmental protection

### 1. INTRODUCTION

Due to growing global production of energy the reducing greenhouse gas emissions is an immensely challenging task because this production is largely dependent on fossil fuels. In the XX century the increase of global population, production and consumption what caused decline in natural carbon sequestration capacity and so significant surge level of the greenhouse gas. No method of effective carbon dioxide elimination is currently used on a mass scale. Moreover, currently it does not seem that such method will be used in the foreseeable future. Currently, reducing greenhouse gas emissions is

---

<sup>1</sup> Institute of Environmental Engineering and Biotechnology, University of Opole, ul. Kard. B. Kominka 6a, 45-032 Opole, Poland, barbara.wlodarczyk@uni.opole.pl, +48 77 401 60 48

achieved mainly through curbing the rise in greenhouse gas emissions by reducing the energy intensity and by enhancing energy efficiency of production [1,2]. Therefore, it is necessary to develop a new energy platform that will simultaneously ensure increased energy security and the reducing carbon dioxide emissions. One of the future solutions is to use wastewater as an energy source and at the same time the reduce greenhouse gas emissions by the eliminating of incineration process [3-5]. Due to planning to 2050 achieving carbon neutrality, it will be necessary not only change in energy production technology but also lifestyle changes. A significant lifestyle change may be difficult for society to accept, mainly due to the planned increase in energy prices and planned limits on energy consumption [5-9].

With the growth of the world's population the amount of waste or wastewater still growing and requires more and more financial expenditures for its treatment. [10-12]. A large part of waste substances are organic substances contained in wastewater. There are many methods of disposal, e.g., waste incineration, biogas production, treating wastewater with the use of activated carbon or the Fenton reaction [3-5,13-15]. However, wastewater contains several times more energy than it is needed for its disposal and therefore it would be important to recover some of this energy for energy purposes [4,9]. One of the technologies that can be used to recover energy from wastewater is a microbial fuel cell (MFC) technology [4,10-12]. MFC is electro-bio-chemical system in which bioelectricity is produced by microorganisms fed by wastewater. In MFC the microorganisms act as catalysts [2,13,15]. Using MFC technology, it is possible to generate bioelectricity but simultaneously they can be supporting element of wastewater treatment in wastewater treatment plant due mainly on reduce the chemical oxygen demand (COD) [16-22].

The MFC to produce energy can use any biodegradable source of organic matter, from pure compounds to, e.g., wastewater [23,24]. In the MFCs the microorganisms act as a catalyst of anode [4,10,11,16,25]. Microorganisms that are produce bioelectricity include, e.g., *Clostridia*, *Bacteroidetes* or fungi as, e.g., *Saccharomyces* [10,11,26-33]. However, there are also other microorganisms present in the MFC anode chamber, which have not yet been fully determined [30,34]. Microorganisms for MFC are obtained from bottom sediments, soil or from wastewater treatment plants (activated sludge) and from previously operating MFC [4,32,35-40].

The MFCs using biomass accumulated in organic wastewater are renewable energy sources as nature-friendly renewable energy sources of the future [26-30,31-34,41-46]. However, for MFCs to be used on a large scale, it is necessary to increase their efficiency. Currently the main disadvantage of MFCs is low current density [4,16,19,20,23,24]. The low value of this parameter results mainly from the low metabolic rate of the microorganisms which act as a catalyst. But MFC operation is also influenced by the electrode material or the type of wastewater [22,48-52] or using mediators [10,53]. However, due to low rate of metabolism the obtaining amount of electricity is low. It is due the fact that the obtaining current density is directly proportional to the reaction rate on anode (in case of MFC, to rate of microorganisms' metabolism) [4,5,54].

Various types of wastewaters can be used as food for microorganisms in MFCs, both municipal and industrial wastewater [55-60]. The examples of industrial wastewater used in MFCs can be, e.g., tannery wastewater [61] or electroplating industry wastewater [62]. However, the most beneficial are wastewater from the food industry [63]. Various wastewaters from food industry are used in MFCs research, depending on availability (depending on the world region, type of crops or on the type/advancement of the food industry). For research are used the wastewater from production from fruits and vegetables processing, e.g., brewery wastewater [64,65], waste of papaya [56], banana [66], golden berry [67], blueberry [68], onion [69], as well as yeast wastewater [57-58].

Municipal wastewater contains many undesirable compounds and substances for the operating of MFCs. Examples include detergents, soap, heavy metals, and dangerous viruses and pathogenic bacteria

that enter the wastewater along with feces. Whereas the composition of process wastewater from the food industry is strictly defined and these types of contamination are eliminated. Therefore, it would be important to enrich the municipal wastewater with the process wastewater. Mixing both types of wastewaters will provide additional portions of organic substances and will also reduce the overall concentration of the above-mentioned unfavorable compounds and substances. Moreover, feeding the microorganisms in the anode chamber with such mixed wastewater should improve the operating of the MFC. In this work the feeding membrane-less microbial fuel cell (ML-MFC) by the mixed municipal and process wastewater was analyzed.

## 2. MATERIALS AND METHODS

For analysis as industrial wastewater the process wastewater from yeast production was selected. In the yeast factory the process wastewater (PWW) is produced at the stage of molasses clarification, centrifugation, and vacuum filtering. These wastewater as fertilizer is mainly directed to agricultural fields [70,71]. Figure 1 shows the formations points of the process wastewater in the yeast production. In this study, the most concentrated wastewater from yeast production was selected for mixing with municipal wastewater. This wastewater was collected from molasses clarification streams and from the first centrifuge. Process wastewater from these streams was mixed in equal proportions (50:50). This mixture represented technological wastewater for further measurements.

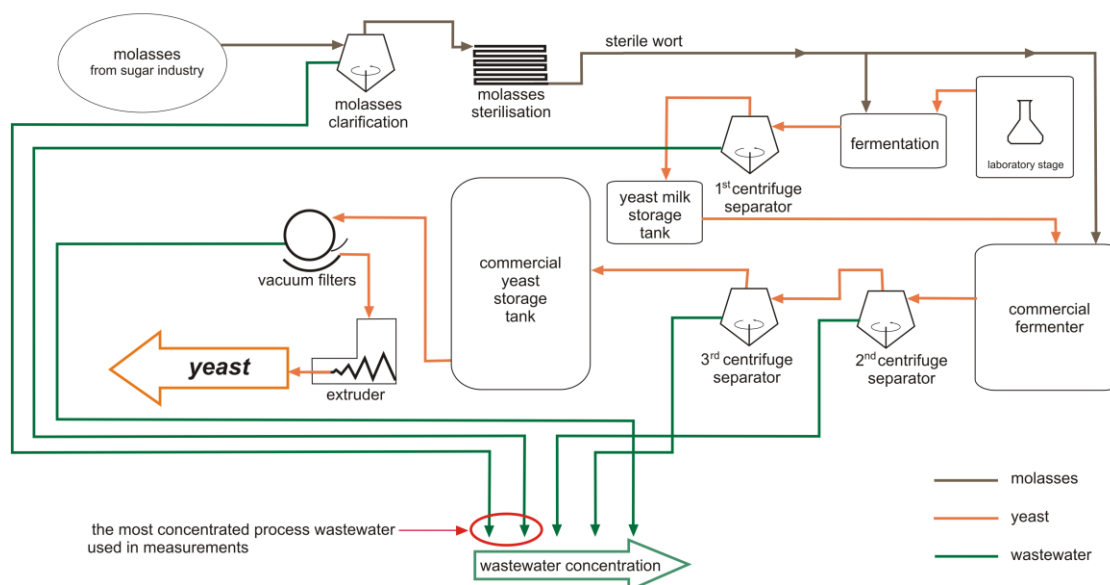

Fig. 1. Yeast production line with the formations points of the PWW

Process wastewater from selected sources (from molasses clarification and from the first centrifuge) has a very high concentration of pollutants. Therefore, it was decided to add to municipal wastewater (MWW) a small amount of process wastewater. In measurements added 0, 5, 10, 15, and 20% of the process wastewater to the municipal wastewater.

The measurement was divided into two stages: the analysis of the chemical oxygen demand (COD) reduction, and the analysis of the electrical parameters during MFC operation. In case of the

COD reduction the Hanna HI-801 Iris spectrophotometer (HANNA Instruments, Woonsocket, RI, USA) was used. Whereas in case of the measurements of the electrical parameters the cell voltage, power, and current density was measured where a Fluke 8840A multimeter (Fluke Corporation, Everett, WA, USA) and a PGSTAT302N potentiostat (Metrohm-Autolab BV, Utrecht, Holland) was used.

For measurements the membrane-less microbial fuel cell (ML-MFC) with the chambers placed one above the other was selected. The anode chamber was placed at the bottom, and the cathode chamber was placed above the anode chamber. The chambers are separated by a layer of glass wool. Placement of chambers and separator (glass wool) ensures limited oxygenation of the anode chamber. Fresh wastewater flows into the anode chamber from an external tank, and only after the organic matter has been used by microorganisms, the wastewater slowly flows by the separator to the upper cathode chamber. Only there is the wastewater oxygenated and then directed back to the external tank. Moreover, elimination of proton exchange membrane (PEM) allows to reduction of build cost (the PEM is often the most expensive component of MFC). Therefore, this type of cell to research was chosen [57]. The ML-MFC housing was printed by the 3D printing technology (Zortrax M200 3D printer with the Z-Suite software; Zortrax S.A, Olsztyn, Poland). For printing the HIPS plastic was used.

As an anode the carbon felt was used. Whereas, as a cathode the carbon cloth was used. During the operation of ML-MFC the cathode (in cathode chamber) was constantly aerated ( $2 \text{ L}\cdot\text{h}^{-1}$ ) by air stone bubbler. The external load ( $100 \Omega$ ) was used to connect the electrodes (to close the electrical circuit) [5,16,22]. Before using the municipal and industrial wastewater in to the MFC, the microorganisms by 5 days were acclimatized [16,72].

For comparison of effectiveness of COD reduction after adding the process wastewater the three different reactor was used. First: reactor without aeration (control measurement), second: reactor with aeration, and third: ML-MFC [72]. Glass aquariums with a capacity of 15 L were used as the First and Second reactors. In reactor without aeration the wastewater was inoculated with passive air only through the interface of the wastewater [22,58,72]. In reactor with aeration the wastewater was constantly aerated ( $200 \text{ L}\cdot\text{h}^{-1}$ ). The reactors without and with aeration was of 15 L capacity. Initial COD concentration of mixed wastewater was  $1413 \pm 50 \text{ mg}\cdot\text{L}^{-1}$  for 0% addition of PWW,  $2980 \pm 50 \text{ mg}\cdot\text{L}^{-1}$  for 5% addition of PWW,  $4547 \pm 50 \text{ mg}\cdot\text{L}^{-1}$  for 10% addition of PWW,  $6114 \pm 50 \text{ mg}\cdot\text{L}^{-1}$  for 15% addition of PWW, and  $7680 \pm 50 \text{ mg}\cdot\text{L}^{-1}$  for 20% addition of PWW. COD concentration measurements were performed both before and during the measurements, at one-day intervals. To comparison of the effectiveness of COD reduction of the ML-MFC with the reactor without aeration and reactor with aeration the ML-MFC was combined with external wastewater tank (with slow circulation of  $0.05 \text{ L}\cdot\text{h}^{-1}$  in a closed loop). To allow comparison to the capacity of the other reactors the volume of wastewater in the entire system was 15 L (MFC + an external tank). The external tank was much larger than the capacity of the MFC to ensure constant access to fresh wastewater. And the flow was slow enough to allow for a permanent supply of nutrients (for microorganisms). Furthermore, the slow flow, together with the very slow mixing of the wastewater in the external tank, minimized the oxygenation of the wastewater supplied to the anode chamber. All reactors were operated until 90% COD reduction was achieved [72].

### 3. RESULTS AND DISCUSSION

In first step the reduction of COD concentration was analyzed in three reactors (Figure 3). All reactors (R1, R2, and R3) were fed with the same wastewater. Figure 2-6 contains details of the reduction of COD over time for the three types of reactors, and with addition accordingly of 0, 5, 10, 15 and 20% of the PWW.

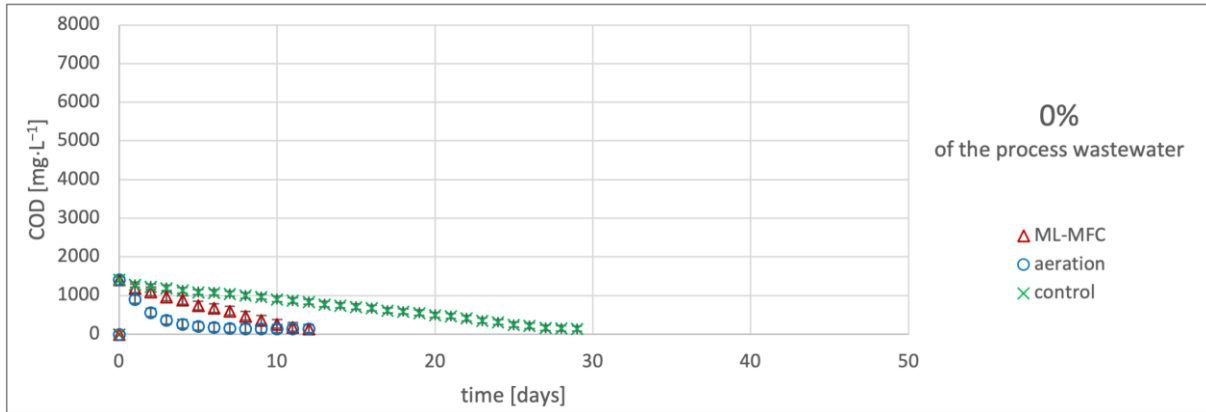

Fig. 2. Reduction of the COD in wastewater without adding PWW

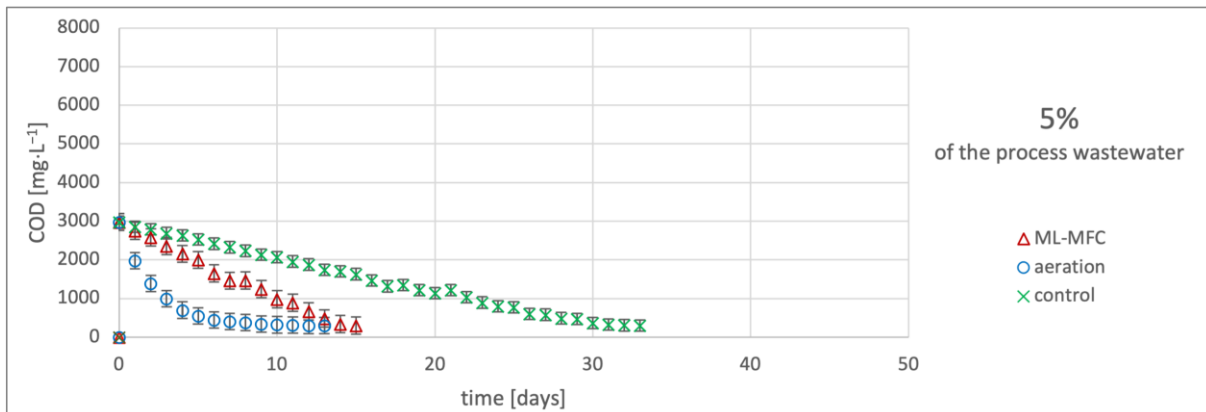

Fig. 3. Reduction of the COD in wastewater with addition 5% of the PWW

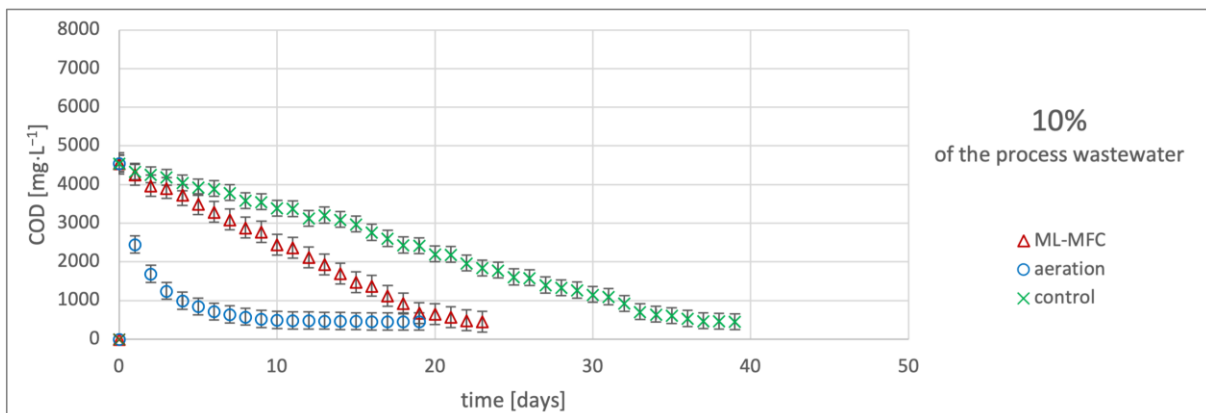

Fig. 4. Reduction of the COD in wastewater with addition 10% of the PWW

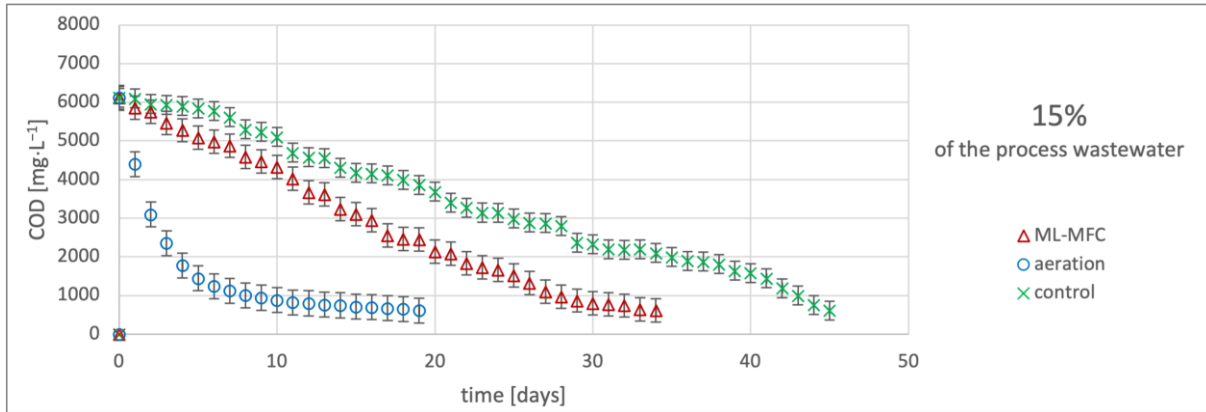

Fig. 5. Reduction of the COD in wastewater with addition 15% of the PWW

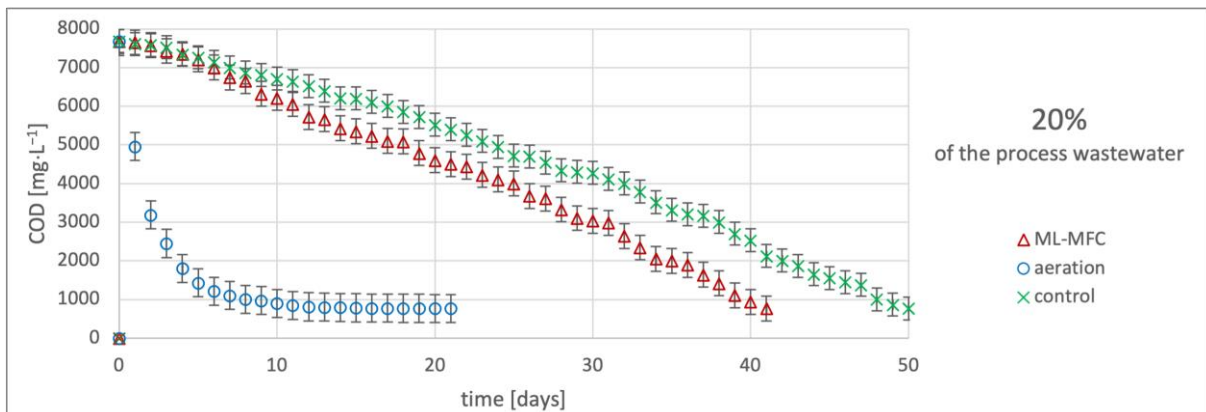

Fig. 6. Reduction of the COD in wastewater with 20% of the PWW

According to the data obtained (Figures 4-6), a reduction of COD to 90% were obtained for all reactor types and for all PWW concentrations. Depending on the type of reactor (without aeration, with aeration or MFC), the reduction time varied. The initial values of COD concentration were different depending on the amount of added PWW. Due to the high COD value, the addition of PWW increases the concentration of the mixture used for measurements (Figures 4-6). In the case of MWW (without the addition of PWW), the COD reduction time without aeration was 29 days, whereas the reduction time for aeration and MFC was 12 days (Figure 2). However, the characteristic of curve for aeration is more beneficial because the COD reduction is much more intense than when using MFC. However, unlike MFC, aeration requires significant amounts of energy.

The higher the concentration of PWW, the longer the time required for COD reduction to the desired level. However, it should be noted that at the same time the difference between the reduction time for the reactor without aeration and for the MFC decreases (Figures 4-6; green cross markers, and red triangular markers). In the case of MWW (without addition of the PWW), the COD reduction time for MFC is 41% of the reduction time for control measurement (without aeration). And accordingly for 5% PWW addition - 45% of control measurement time (CMT) (Figure 3), for 10% PWW addition - 59% of CMT (Figure 4), for 15% PWW addition - 76% of CMT (Figure 5), and for 15% PWW addition - 82% of CMT (Figure 6). It should also be noted that in each case, for all PWW concentrations, the

COD decline curve for aeration is the most beneficial. But as noted earlier, oxygenation (aeration) requires significant energy expenditure.

Next, the electrical parameters during ML-MFC operation were analyzed. First, the current density was measured. Because the biofilm was covered the entire surface of the dense carbon felt (anode), all electrode pores were aligned with the biofilm during the MFC operation. Therefore, the anode surface was determined as the geometric surface of the electrode. And this value was used for determining of current density. Table 1 presents the current density obtained during ML-MFC operation, and with addition accordingly of 0, 5, 10, 15 and 20% of the PWW.

Table 1. Current density obtained during ML-MFC operation

parameter	0% PWW	5% PWW	10% PWW	15% PWW	20% PWW
current density (max. value) [mA·cm <sup>-2</sup> ]	0.15	0.18	0.26	0.23	0.22

As can be seen from the data in Table 1, the highest value (0.26 mA·cm<sup>-2</sup>) of current density was obtained for 10% of PWW addition in mixed wastewater (which was fed to ML-MFC). The lowest value (0.15 mA·cm<sup>-2</sup>) of this parameter was obtained for 0% of PWW share. In the case of 15 and 20% of PWW, similar current density values were obtained (0.23 mA·cm<sup>-2</sup> for 15% and 0.22 mA·cm<sup>-2</sup> for 20%, respectively). However, these values are noticeably lower than those obtained for 10% PWW addition.

Next, the cell voltage obtained during the operation of the ML-MFC was measurements. The results of these measurements are shown in Figure 7.

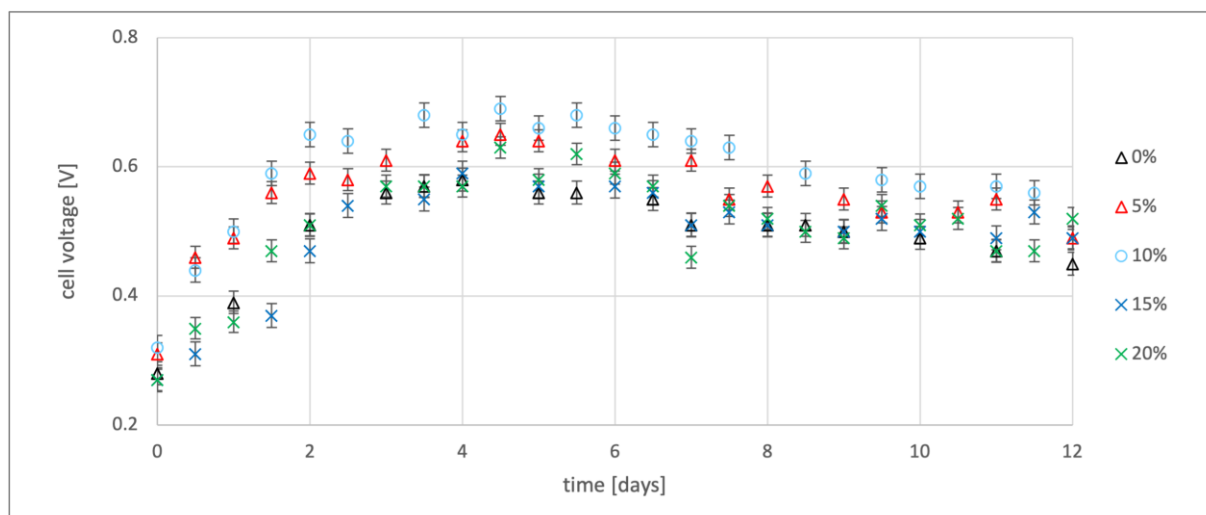

Fig. 7. Cell voltage of the ML-MFC in time, depending on the percentage of PWW

According to the data obtained (Figures 7), the obtained cell voltage value depends on the percentage of PWW addition. The average cell voltage value during 12 days of cell operation for MWW was 500 mV, 554 mV for 5% PWW addition, for 10% PWW addition – 598 mV, for 15% PWW addition - 494 mV, and for 20% PWW addition - 508 V. Whereas the maximum cell voltage values were 0.580 V for 0% of PWW, 0.650 V for 5% of PWW, 0.690 V for 10% of PWW, 0.590 V for 15% of PWW, and

0.630 V for 20% of PWW. It should be noted that the maximum cell voltage values were achieved with 10% of PWW addition. Moreover, it should be noted that the cell voltage increased with increasing the PWW addition up to 10% (when the maximum cell voltage value and the maximum average value over 12 days were reached), and then the voltage decreased with the addition of PWW.

Next, the power curves obtained during the operation of the ML-MFC was measurements. The results of these measurements are shown in Figure 8.

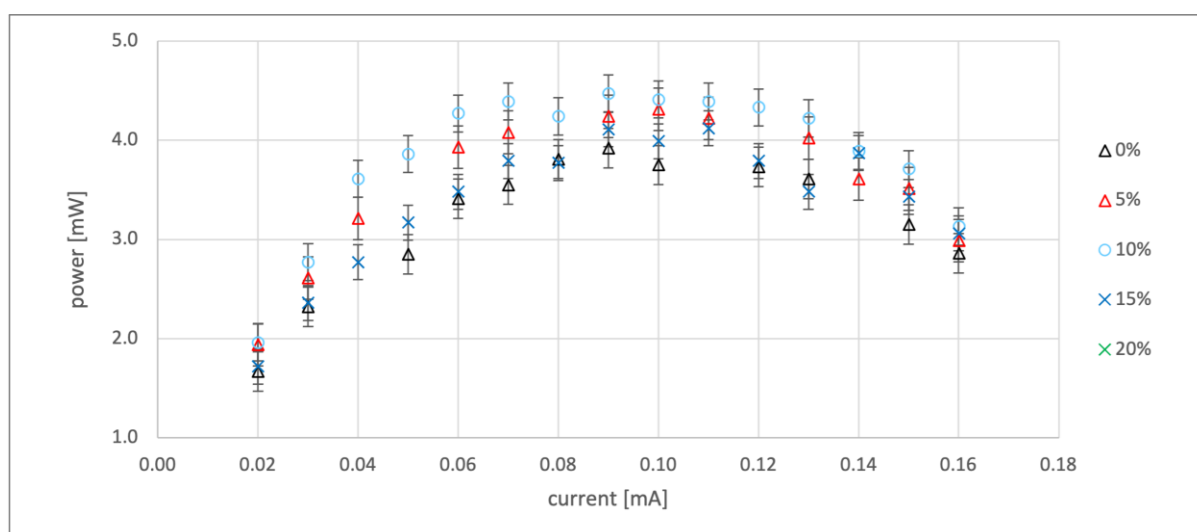

Fig. 8. Power curves of the ML-MFC, depending on the percentage of PWW

According to the measurements obtained (Figures 8), the maximum power value was obtained, similarly to the cell voltage, for 10% PWW addition. Moreover, as with the cell voltage, the power increased with increasing the PWW addition up to 10%, and then the power decreased with the addition of PWW. The maximum cell power was 4.47mW for 10% PWW. However, for 0% PWW the power was 3.92mW, for 5% PWW - 4.31mW, for 15% PWW - 4.12mW, and for 20% PWW - 4.11mW. The maximum value obtained for 10% PWW addition represents approximately a 14% increase in power compared to measurements for 0% PWW addition.

#### 4. CONCLUSIONS

During the study, feeding of ML-MFCs by mixed municipal (MWW) and industrial (PWW) wastewaters was analyzed. The measurements demonstrated that the addition of PWW to the MWW influences the operation of the ML-MFC. In the case of COD concentration reduction measurements, the effect of wastewater concentration (which results from the addition of highly concentrated process wastewater) can clearly be seen. The higher the concentration of PWW, the longer the COD reduction time (mainly due to the increasing concentration of COD). Moreover, at the same time the difference between the reduction time for the reactor without aeration and for the MFC decreases. In fact, the aeration curves indicate that in the case of COD reduction, aeration is more beneficial than the use of MFC. However, oxygenation requires significant energy inputs, which in most treatment plants constitute approximately 50% of the wastewater treatment costs. The use of MFC would not only save on aeration costs, but also allow for a small amount of energy recovery. However, the cell voltage and



power increased with increasing the PWW addition up to 10%, and then these parameters slightly decreased with a further addition of PWW. The average value of the cell voltage (598 mV) for 10% PWW addition was of 19% higher compared to measurements for 0% PWW addition (500 mV). Whereas the maximum power for 10% PWW addition (4.47 mW) represents approximately a 14% increase in power compared to measurements for 0% PWW addition (3.92 mW). In conclusion, under the conditions adopted in the experiment (type of MFC, electrodes, type of wastewater, etc.), the best electrical parameters were obtained for 10% of the addition of yeast process wastewater.

## REFERENCES

1. Stern, N 2005. *The Economics of Climate Change*. Cambridge: Cambridge University Press.
2. Schröter, D, Cramer, W, Leemans, R, Prentice, IC, Araújo, MB, Nigal, W, Arnell, NW, Bondeau, A, Bugmann, H, Carter, TR, Gracia, CA, De La Vega-Leinert, AC, Erhard, M, Ewert, F, Glendinning, M, House, JI, Kankaanpää, S, Klein, RJT, Lavorel, S, Lindner, M, Metzger, MJ, Meyer, J, Mitchell, TD, Reginster, I, Rounsevell, M, Sabaté, S, Sitch, S, Smith, B, Smith, J, Smith, P, Sykes, M.T, Thonicke, K, Thuiller, W, Tuck, G, Zaehle, S, Zierl, B 2005. Ecosystem Service Supply and Vulnerability to Global Change in Europe. *Science* **310** (5752), 1333-1337.
3. Rabaey, K and Verstraete, W 2005. Microbial fuel cells: Novel biotechnology for energy generation. *Trends Biotechnol.* **23**, 291–298.
4. Logan, B 2008. *Microbial Fuel Cells*. Hoboken: Wiley.
5. Franks, AE and Nevin, KP 2010. Microbial fuel cells, a current review. *Energies* **3** (5), 899-919.
6. Tsiropoulos, I, Siskos, P, Capros, P 2022. The cost of recharging infrastructure for electric vehicles in the EU in a climate neutrality context: Factors influencing investments in 2030 and 2050. *Applied Energy* **322**, 119446.
7. Wiese, F, Thema, J, Cordroch, L 2022. Strategies for climate neutrality. Lessons from a meta-analysis of German energy scenarios. *Renewable and Sustainable Energy Transition* **2**, 100015.
8. Wolf, S, Teitge, J, Mielke, J, Schütze, F, Jaeger, C 2021. The European Green Deal — More Than Climate Neutrality. *Intereconomics* **56**, 99–107
9. Zhang, X and Zheng, R 2020. Reducing building embodied emissions in the design phase: A comparative study on structural alternatives. *Journal of Cleaner Production* **243**, 118656.
10. Bartkiewicz, B and Umiejewska, K 2020. *Oczyszczanie ścieków Przemysłowych*; Warszawa: Wydawnictwa Naukowe PWN.
11. Sadecka, Z 2010. *Podstawy biologicznego oczyszczania ścieków*. Józefosław: Wydawnictwo Seidel-Przywecki.
12. Shizas, I and Bagley, D 2004. Experimental determination of energy content of unknown organics in municipal wastewater streams. *J. Energy Eng.* **130**, 45–53.
13. Cieślik, BM, Namieśnik, J, Konieczka, P 2015. Review of sewage sludge management: standards, regulations and analytical methods. *Journal of Cleaner Production* **90**, 1-15.
14. Ruppert, G, Bauer, R, Heisler, G 1993. The photo-Fenton reaction — an effective photochemical wastewater treatment process. *Journal of Photochemistry and Photobiology A: Chemistry* **73** (1), 75-78.
15. Syed-Hassan, SSA, Wang, Y, Hu, S, Su, S, Xiang, J 2017. Thermochemical processing of sewage sludge to energy and fuel: Fundamentals, challenges and considerations. *Renewable and Sustainable Energy Reviews* **80**, 888-913.
16. Logan, BE, Hamelers, B, Rozendal, R, Schroder, U, Keller, J, Verstraete, W, Rabaey, K 2006. Microbial fuel cells: Methodology and technology. *Environ. Sci. Technol.* **40**, 5181–5192.

17. Malik, S, Kishore, S, Dhasmana, A, Kumari, P, Mitra, T, Chaudhary, V, Kumari, R, Bora, J, Ranjan, A, Minkina, T, Rajput, VD 2023. A Perspective Review on Microbial Fuel Cells in Treatment and Product Recovery from Wastewater. *Water* **15**, 316.
18. Min, B and Logan, BE 2004. Continuous electricity generation from domestic wastewater and organic substrates in a flat plate microbial fuel cell. *Environ. Sci. Technol.* **38**, 5809–5814.
19. Munoz-Cupa, C.; Hu, Y.; Xu, C.; Bassi, A. An overview of microbial fuel cell usage in wastewater treatment, resource recovery and energy production. *Science of The Total Environment* **754**, 142429.
20. Saha, TC, Protity, AT, Zohora, FT, Shaha, M, Ahmed, I, Barua, E, Sarker, PK, Mukherjee, SK, Savvidou, MG, Pandis, PK, Mamma, D, Sourkouni, G, Argiris, C 2022. Organic Waste Substrates for Bioenergy Production via Microbial Fuel Cells: A Key Point Review. *Energies* **15**, 5616.
21. Sharan, S, Khare, P, Shankar, R, Patel, RK, Mondal, P 2021. Simultaneous removal of organics and bioenergy production by microbial fuel cell: modeling approach. *International Journal of Chemical Reactor Engineering* **19** (12), 1351-1362.
22. Włodarczyk, PP and Włodarczyk, B 2019. Wastewater treatment and electricity production in a microbial fuel cell with Cu–B alloy as the cathode catalyst. *Catalysts* **9**, 572.
23. Logan BE and Regan JM 2006. Electricity-producing bacterial communities in microbial fuel cells. *Trends in Microbiology* **14** (12), 512–518.
24. Wang, X, Feng, YJ, Lee, H 2008. Electricity production from beer brewery wastewater using single chamber microbial fuel cell. *Water Science & Technology* **57** (7), 1117–1121.
25. Erazo, S and Agudelo-Escobar, LM 2023. Determination of Electrogenic Potential and Removal of Organic Matter from Industrial Coffee Wastewater Using a Native Community in a Non-Conventional Microbial Fuel Cell. *Processes* **11**, 373.
26. Bond, DR and Lovley, DR 2003. Electricity production by *Geobacter sulfurreducens* attached to electrodes. *Applied and Environmental Microbiology* **69**, 1548-1555.
27. Bond, DR and Lovley, DR 2005. Evidence for involvement of an electron shuttle in electricity generation by *Geothrix fermentans*. *Appl. Environ. Microbiol.* **71** (4), 2186–2189.
28. Chaudhuri, SK and Lovley, DR 2003. Electricity generation by direct oxidation of glucose in mediatorless microbial fuel cells. *Nature Biotechnology* **21** (10), 1229-1232.
29. Kim, HJ, Park, HS, Hyun, MS, Chang, IS, Kim, M, Kim, BHA 2022. Mediator-Less Microbial Fuel Cell Using a Metal Reducing Bacterium, *Shewanella Putrefaciens*. *Enzyme and Microbial Technology* **30**, 145-152.
30. Markowska, K, Grudniak, AM, Wolska, KI 2013. Mikrobiologiczne ogniwa paliwowe: Podstawy technologii, jej ograniczenia i potencjalne zastosowania. *Postępy Mikrobiologii* **52** (1), 29–40.
31. Pham, CA, Jung SJ, Phung, NT, Lee, J, Chang, IS, Kim, BH, Yi, H, Chun, J 2003. A novel electrochemically active and Fe(III)-reducing bacterium phylogenetically related to *Aeromonas hydrophila*, isolated from a microbial fuel cell. *FEMS Microbiology Letters* **223** (1), 129-134.
32. Pham, TH, Rabaey, K, Aelterman, P, Clauwaert, P 2006. De Schampelaire L., Boon N., Verstraete W. Microbial fuel cells in relation to conventional anaerobic digestion technology. *Engineering in Life Science* **6**, 285–292.
33. Reguera, G, Nevin, KP, Nicoll, JS, Covalla, SF, Woodard, TL, Lovley, DR 2006. Biofilm and nanowire production leads to increased current in *Geobacter sulfurreducens* fuel cells. *Appl. Environ. Microbiol.* **72** (11), 7345–7348.
34. Reguera, G, McCarthy, KD, Mehta, T, Nicoll, JS, Tuominen, MT, Lovley, DR 2005. Extracellular electron transfer via microbial nanowires. *Nature* **435** (7045), 1098–1101.
35. Aelterman, P, Rabaey, K, Pham, HT, Boon, N, Verstraete, W 2006. Continuous electricity generation at high voltages and currents using stacked microbial fuel cells. *Environmental Science & Technology* **40** (10), 3388–3394.

36. Kiżys, K, Zinovičius, A, Jakštys, B, Bružaitė, I, Balčiūnas, E, Petrulevičienė, M, Ramanavičius, A, Morkvėnaitė-Vilkončienė, I 2023. Microbial Biofuel Cells: Fundamental Principles, Development and Recent Obstacles. *Biosensors* **13**, 221.
37. Lee, J, Phung, NT, Chang, IS, Kim, BH, Sung, HC 2003. Use of acetate for enrichment of electrochemically active microorganisms and their 16S rDNA analyses. *FEMS Microbiology Letters* **223** (2), 185–191.
38. Patil, SA, Surakasi, VP, Koul, S, Ijmulwar, S, Vivek, A, Shouche, YS, Kapadnis, BP 2009. Electricity generation using chocolate industry wastewater and its treatment in activated sludge based microbial fuel cell and analysis of developed microbial community in the anode chamber. *Bioresource Technology* **100** (21), 5132–5139.
39. Sun, J, Li, Y, Hu, Y, Hou, B, Xu, Q, Zhang, Y, Li, S 2012. Enlargement of anode for enhanced simultaneous azo dye decolorization and power output in air-cathode microbial fuel cell. *Biotechnology Letters* **34** (11), 2023–2029.
40. Zhang, G, Wang, K., Zhao, Q, Jiao, Y, Lee, DJ 2012. Effect of cathode types on long-term performance and anode bacterial communities in microbial fuel cells. *Bioresource Technology* **118**, 249–256
41. Beegle, JR and Borole, AP 2018. Energy production from waste: Evaluation of anaerobic digestion and bioelectrochemical systems based on energy efficiency and economic factors. *Renewable and Sustainable Energy Reviews* **96**, 343–351.
42. Maureira, D, Romero, O, Illanes, A, Wilson, L, Ottone, C 2023. Industrial bioelectrochemistry for waste valorization: State of the art and challenges. *Biotechnology Advances* **64**, 108123.
43. Moradian, JM, Xu, ZA, Shi, YT, Fang, Z, Yong, YC 2019. Efficient biohydrogen and bioelectricity production from xylose by microbial fuel cell with newly isolated yeast of *Cystobasidium slooffiae*. *International Journal of Energy Research* **44**, 325–333.
44. Dumas, C, Mollica, A, Féron, D, Basséguy, R, Etcheverry, L, Bergel, A 2006. Marine microbial fuel cell: Use of stainless steel electrodes as anode and cathode materials. *Electrochimica Acta* **53**, 468–473.
45. Martin, E, Tartakovsky, B, Savadogo, O 2011. Cathode materials evaluation in microbial fuel cells: A comparison of carbon,  $Mn_2O_3$ ,  $Fe_2O_3$  and platinum materials. *Electrochimica Acta* **58**, 58–66.
46. Tsai, HY, Wu, CC, Lee, CY, Shih, EP 2009. Microbial fuel cell performance of multiwall carbon nanotubes on carbon cloth as electrodes. *Journal of Power Sources* **194** (1), 199–205.
47. Wei, J, Liang, P, Huang, X 2011. Recent progress in electrodes for microbial fuel cells. *Bioresource Technology* **102** (20), 9335–9344.
48. Włodarczyk, B, Włodarczyk, PP 2020. Comparison of Cu-B alloy and stainless steel as electrode material for microbial fuel cell. In: Wróbel, M, Jewiarz, M, Szlęk, A (eds) *Renewable Energy Sources: Engineering, Technology, Innovation 2020. Springer Proceedings in Energy*. Springer, 1057–1063.
49. Włodarczyk, PP, Włodarczyk, B 2022. Feasibility of waste engine oil electrooxidation with Ni-Co and Cu-B catalysts. *Energies* **15**, 7686.
50. Dumas, C, Mollica, A, Féron, D, Basséguy, R, Etcheverry, L, Bergel, A 2006. Marine microbial fuel cell: Use of stainless steel electrodes as anode and cathode materials. *Electrochimica Acta* **53**, 468–473.
51. Tsai, HY, Wu, CC, Lee, CY, Shih, EP 2009. Microbial fuel cell performance of multiwall carbon nanotubes on carbon cloth as electrodes. *Journal of Power Sources* **194** (1), 199–205.
52. Ahn, Y, Logan, BE 2010. Effectiveness of domestic wastewater treatment using microbial fuel cells at ambient and mesophilic temperatures, *Bioresource Technology* **101** (2), 469–475

53. Abedule, AP, Aderiye, BI, Adebayo, AA 2018. Improving bioelectricity generation of microbial fuel cell (MFC) with mediators using kitchen waste as substrate. *Annals of Applied Microbiology & Biotechnology Journal* **2** (1), 1008.
54. Das, D 2018. *Microbial fuel cell, A bioelectrochemical system that converts waste to watts*. Wien: Springer-Verlag.
55. Selihin, NM, Tay, MG 2022. A review on future wastewater treatment technologies: Micro-nanobubbles, hybrid electro-Fenton processes, photocatalytic fuel cells, and microbial fuel cells. *Water Sci. Technol.* **85**, 319–341.
56. Rojas-Flores, S, De La Cruz-Noriega, M, Benites, SM, Delfin-Narciso, D, Luis, A-S, Díaz, F, Luis, C-C, Moises, GC 2022. Electric current generation by increasing sucrose in papaya waste in microbial fuel cells. *Molecules* **27**, 5198.
57. Włodarczyk, PP, Włodarczyk, B 2018. Microbial fuel cell with Ni–Co cathode powered with yeast wastewater. *Energies* **11**, 3194.
58. Włodarczyk, B, Włodarczyk, PP 2020. The membrane-less microbial fuel cell (ML-MFC) with Ni-Co and Cu-B cathode powered by the process wastewater from yeast production. *Energies* **13**, 3976.
59. Abubackar, HN, Biryol, I, Ayol, A 2023. Yeast industry wastewater treatment with microbial fuel cells: Effect of electrode materials and reactor configurations. *International Journal of Hydrogen Energy* **33**, 12424–12432.
60. Wilberforce, T, Sayed, ET, Abdelkareem, MA, Elsaid, K, Olabi, AG 2021. Value added products from wastewater using bioelectrochemical systems: Current trends and perspectives. *J. Water Process Eng.* **39**, 101737.
61. Urbina-Suarez, NA, Machuca-Martínez, F, Barajas-Solano, AF 2021. Advanced Oxidation Processes and Biotechnological Alternatives for the Treatment of Tannery Wastewater. *Molecules* **26**, 3222.
62. Karuppiyah, T, Uthirakrishnan, U, Sivakumar, SV, Authilingam, S, Arun, J, Sivaramakrishnan, R, Pugazhendhi, A 2022. Processing of electroplating industry wastewater through dual chambered microbial fuel cells (MFC) for simultaneous treatment of wastewater and green fuel production. *Int. J. Hydrog. Energy* **47**, 37569–37576.
63. Rojas-Flores, S, De La Cruz Noriega, M, Benites, SM, Gonzales, GA, Salinas, AS, Palacios, FS 2020. Generation of bioelectricity from fruit waste. *Energy Rep.* **6**, 37–42.
64. Feng, Y, Wang, X, Logan, BE, Lee, H 2008. Brewery wastewater treatment using air-cathode microbial fuel cells. *Appl. Microbiol. Biotechnol.* **78**, 873–880.
65. Wen, Q, Wu, Y, Cao, D, Zhao, L, Sun, Q 2009. Electricity generation and modeling of microbial fuel cell from continuous beer brewery wastewater. *Bioresour. Technol.* **100**, 4171–4175.
66. Verma, M, Mishra, V 2023. Bioelectricity generation by microbial degradation of banana peel waste biomass in a dual-chamber *S. cerevisiae*-based microbial fuel cell. *Biomass and Bioenergy* **168**, 106677.
67. Segundo, R-F, De La Cruz-Noriega, M, Nazario-Naveda, R, Benites, SM, Delfin-Narciso, D, Angelats-Silva, L, Díaz, F 2022. Golden berry waste for electricity generation. *Fermentation* **8**, 256.
68. Rojas-Flores, S, Benites, SM, De La Cruz-Noriega, M, Cabanillas-Chirinos, L, Valdiviezo-Dominguez, F, Quezada Álvarez, MA, Vega-Ybañez, V, Angelats-Silva, L 2021. Bioelectricity production from blueberry waste. *Processes* **9**, 1301.
69. Segundo, R-F, De La Cruz-Noriega, M, Milly Otiniano, N, Benites, SM, Esparza, M, Nazario-Naveda, R 2022. Use of Onion Waste as Fuel for the Generation of Bioelectricity. *Molecules* **27**, 625.

70. Włodarczyk, B, Włodarczyk, PP 2019. Analysis of the potential of an increase in yeast output resulting from the application of additional process wastewater in the evaporator station. *Appl. Sci.* **9** (11), 2282.
71. Włodarczyk, B, Włodarczyk, PP 2016. Analysis of possibility of yeast production increase at maintained carbon dioxide emission level. *Civil and Environmental Engineering Reports* **23** (4), 163–176.
72. Huggins, T, Fallgren, PH, Jin, S, Ren, ZJ 2013. Energy and performance comparison of microbial fuel cell and conventional aeration treating of wastewater. *J. Microb. Biochem. Technol.* **S6:002**, 1–5.